

10x40-50
10x40-60
10x40-75
10x40-100

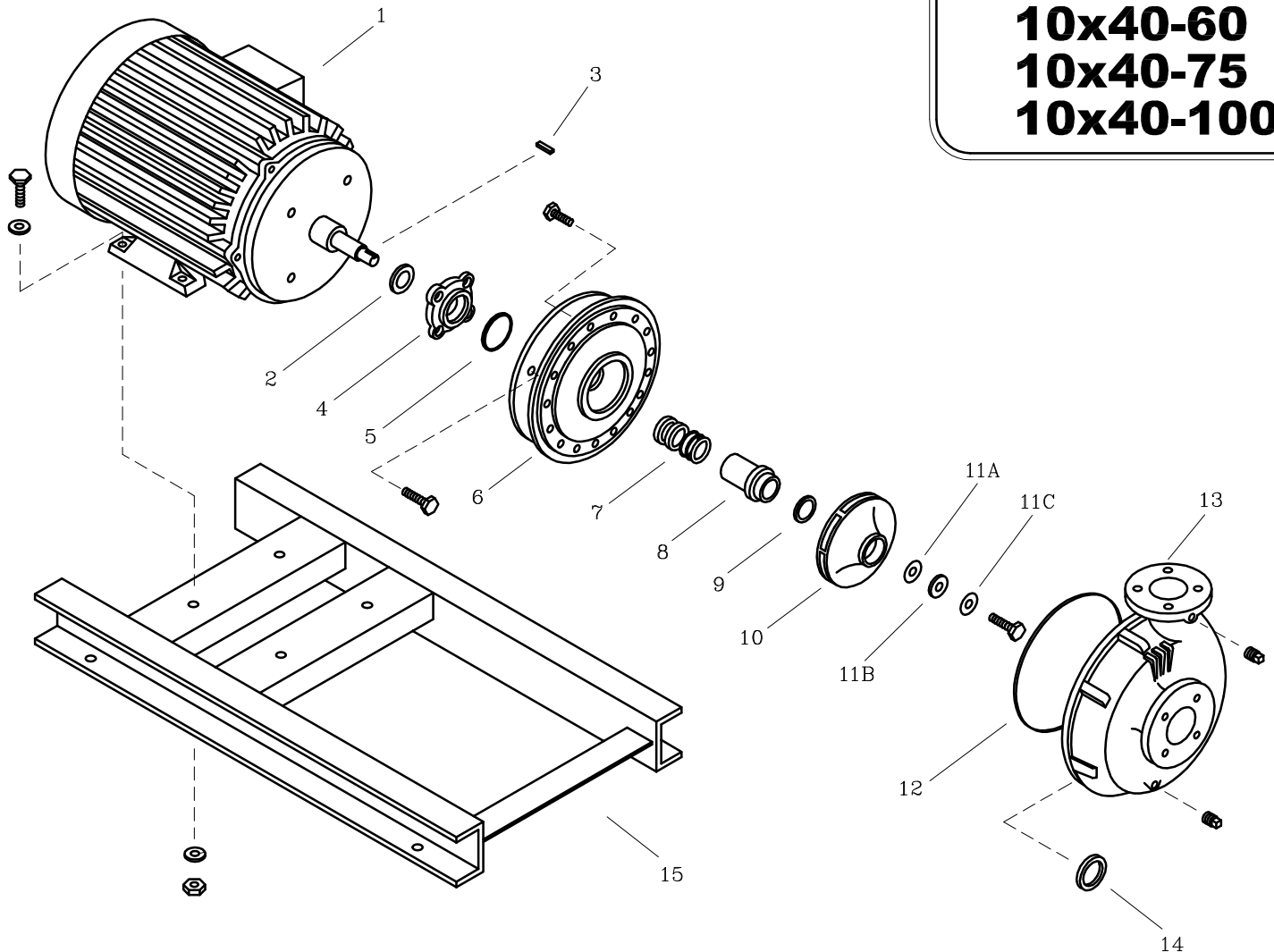

LISTA DE REPUESTOS			CANTIDAD			
ITEM No.	DESCRIPCION	CODIGO	10x40-50	10x40-60	10x40-75	10x40-100
* 1	MOTOR ELECTRICO 1750 RPM	SEGUN POTENCIA	1	1	1	1
2	DEFLECTOR 43.5 mm. DIA. INT.	7800600051	1	1	1	1
3	CUÑA 1/4"x45 mm.	7711500041	1	1	1	1
4	PRENSA SELLO EUROLINEA T3-326	03041C0041	1	1	1	1
5	AROSSELLO REF. 2-150	0306000051	1	1	1	1
6	PLATO SELLO EUROLINEA T3-326JM	0307700021	1	1	1	1
7	SELLO MECANICO ø1.1/2" TIPO 21	7712000051	1	1	1	1
8	CASQUILLO S.M. 10x40-100	89174C0041	1	1	1	1
9	AROSSELLO ROTOR	7711300051	1	1	1	1
10	ROTOR 10x40-50 330 mm.	03081C0021	1	-	-	-
10	ROTOR 10x40-60 340 mm.	03081B0021	-	1	-	-
10	ROTOR 10x40-75 360 mm.	03081A0021	-	-	1	-
10	ROTOR 10x40-100 405 mm.	0308100021	-	-	-	1
11A	EMPAQUE ARANDELA ROTOR	7711600043	1	1	1	1
11B	ARANDELA ROTOR 17/32" DI x 48 DE	0307800041	1	1	1	1
11C	ARANDELA DE COBRE 17/32"	8837700056	1	1	1	1
12	EMPAQUE CARCASA 12x40	8839200043	1	1	1	1
13	CARCASA ANILLO 10x40	9100400021	1	1	1	1
14	ANILLO DE FRICCION 10x40	9100700022	1	1	1	1
15	BASE 10x40-50	0407200046	1	-	-	-
15	BASE 10x40-60-75	0310800046	-	1	1	-
15	BASE 10x40-100	0310900046	-	-	-	1

* Para servicio o reparacion del motor, tenga en cuenta el modelo y características contenidas en la placa del mismo.

- Tornilleria estandar se ilustra unicamente.