

4x26-25
4x26-30
4x26-40
4x26-50

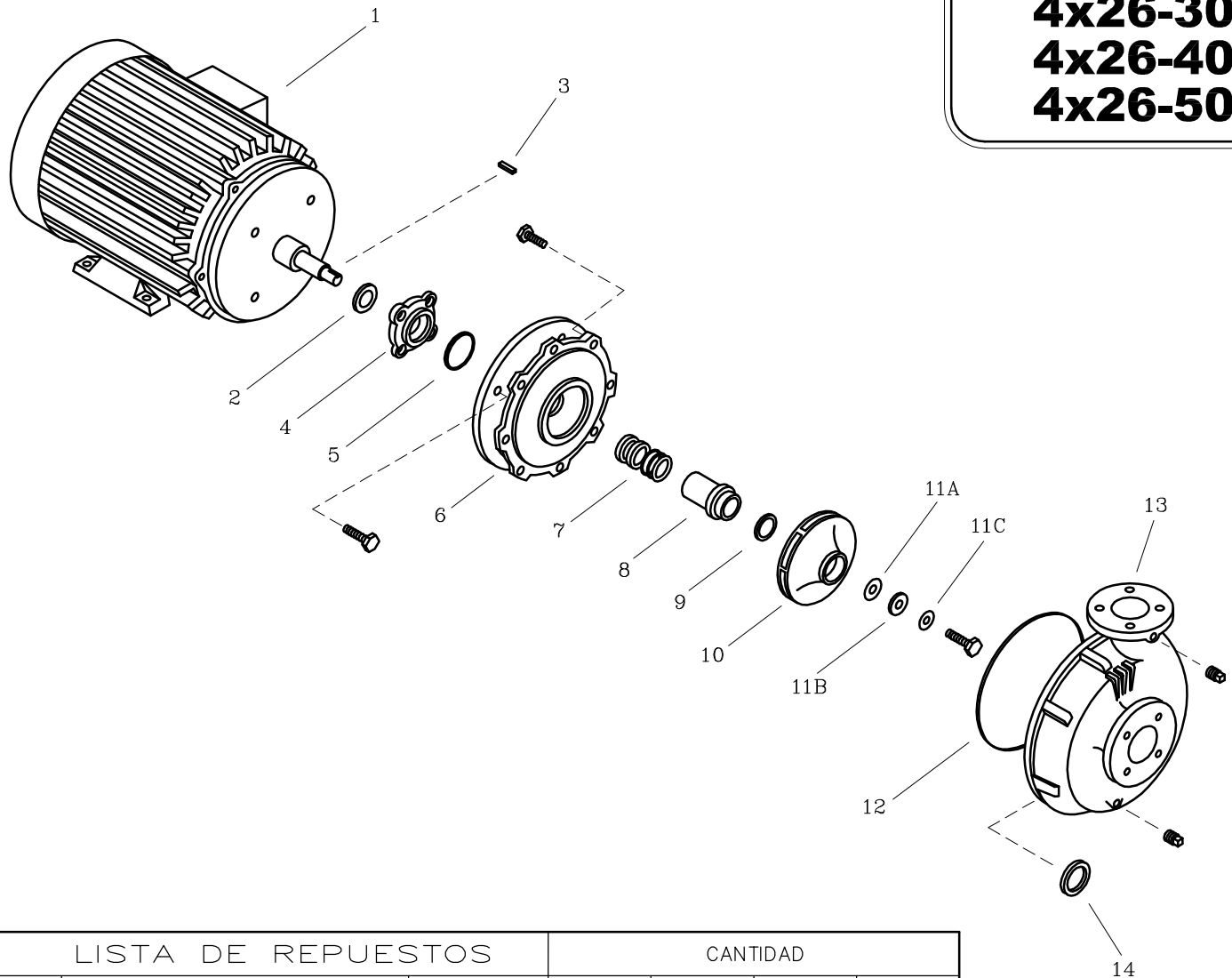

LISTA DE REPUESTOS			CANTIDAD			
ITEM No.	DESCRIPCION	CODIGO	4x26-25W	4x26-30W	4x26-40	4x26-50
* 1	MOTOR ELECTRICO 3500 RPM	SEGUN POTENCIA	1	1	1	1
2	DEFLECTOR 43.5 mm. DIA. INT.	7800600051	1	1	1	1
3	CUÑA 1/4"x32 mm.	7220500041	1	1	1	1
4	PRENSA SELLO EUROLINEA T1-326	03041A0041	1	1	1	1
5	AROSSELLO REF. 2-150	0306000051	1	1	1	1
6	PLATO SELLO EUROLINEA T1-256JM	0306200021	1	-	-	-
6	PLATO SELLO EUROLINEA T1-326JM	0305200021	-	1	1	1
7	SELLO MECANICO ϕ 1.1/2" TIPO 21	7712000051	1	1	1	1
8	CASQUILLO S.M. 6x26-75	89174A0041	1	1	1	1
9	AROSSELLO ROTOR	7711300051	1	1	1	1
10	ROTOR 4x26-25 225 mm.	03083C0021	1	-	-	-
10	ROTOR 4x26-30 235 mm.	03083B0021	-	1	-	-
10	ROTOR 4x26-40 245 mm.	03083A0021	-	-	1	-
10	ROTOR 4x26-50 264 mm.	0308300021	-	-	-	1
11A	EMPAQUE ARANDELA ROTOR 5x20	8836800043	1	1	1	1
11B	ARANDELA ROTOR 17/32" DIA. INT.	8836500041	1	1	1	1
11C	ARANDELA DE COBRE 17/32"	8837700056	1	1	1	1
12	EMPAQUE CARCASA 4x26	9301400043	1	1	1	1
13	CARCASA ANILLO 4x26	9300500021	1	1	1	1
14	ANILLO DE FRICCION 4x26	9301300022	1	1	1	1

* Para servicio o reparacion del motor, tenga en cuenta el modelo y características contenidas en la placa del mismo.
 - Tornilleria estandar se ilustra unicamente.